

ROBOTICS & DRONE WORKSHOP

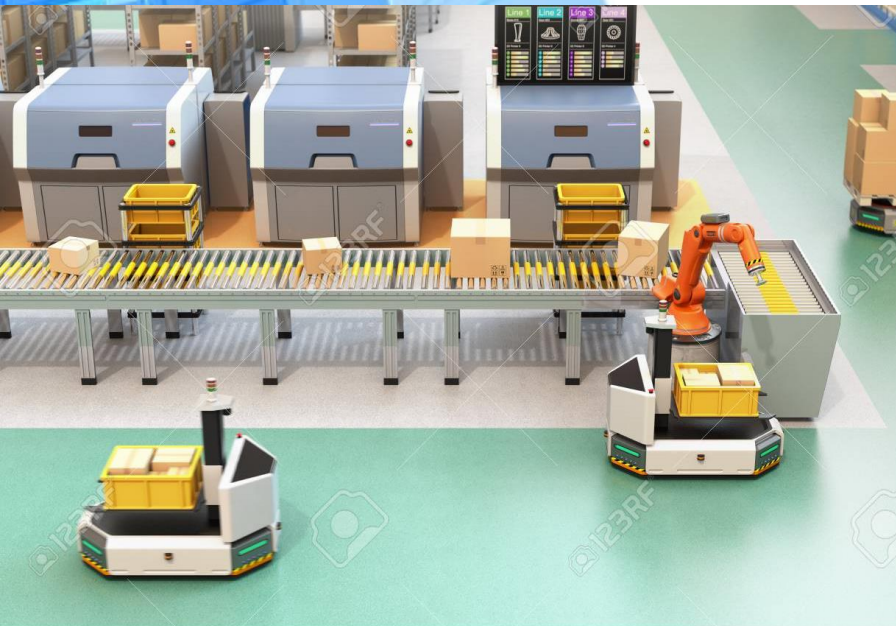

By : Muhammad Aldo Setiawan, S.Si., M.Sc (Eng)

Robotics What? & Why?



Drones or Robotics ?

Robotics



Drones



Robotics Ideal Application

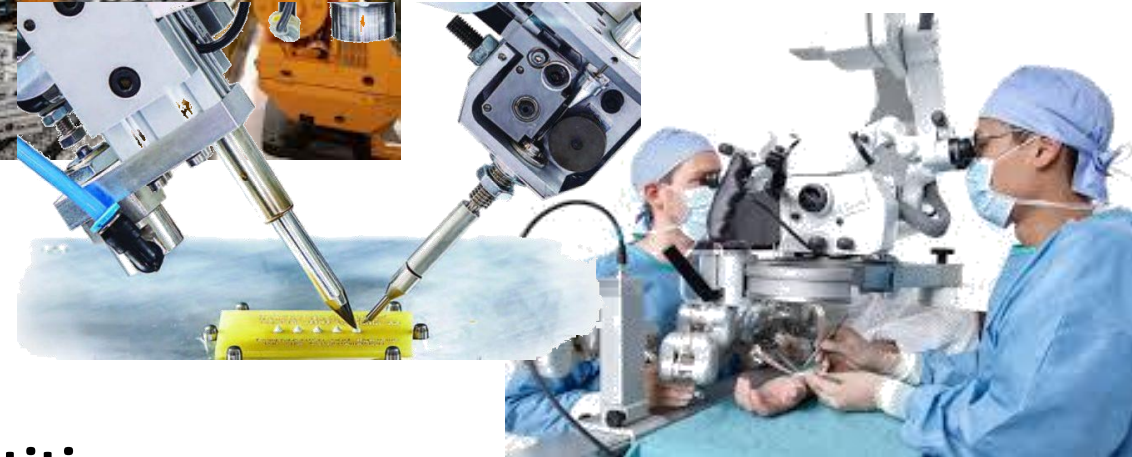

Dangerous or uncomfortable for Human

- Space exploration
- Pet litterbox cleanup
- Disarming bombs

Boring and/or repetitive

- Car manufacture (welding,drilling,etc)
- Pick & place
- Parts assembly

High precision, speed, strength

- Electronic testing
- Precision machining
- Micro-Surgery robotics
- Driving Car

How Robot Works ??

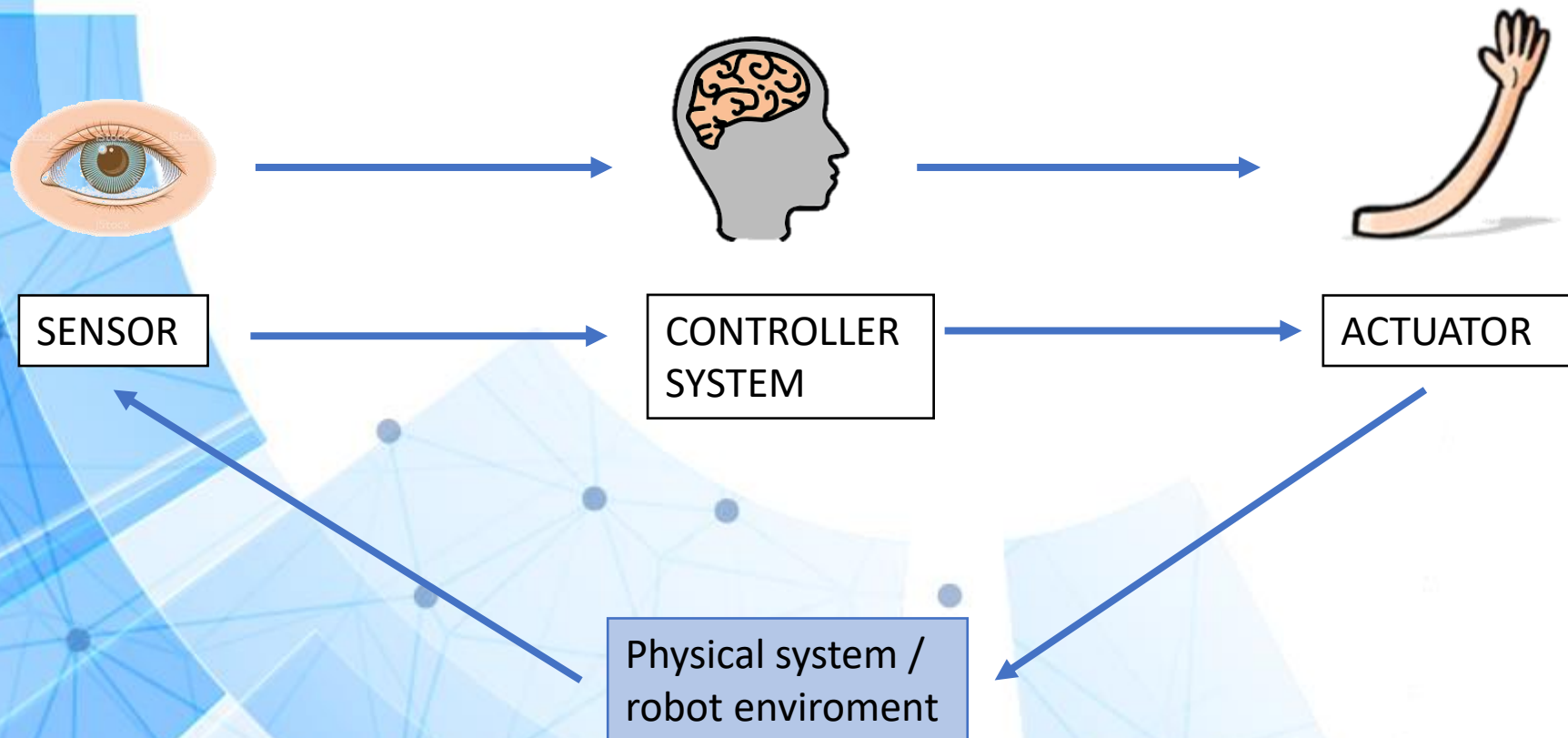

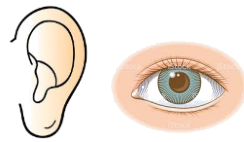

PHYSICAL ENVIRONMENT INPUT

- Force
- Humidity
- Temperature
- Acidity level
- Speed
- Photon
- Magnetic Field
- Pressure
- Color/image
- Rotation
- Acceleration

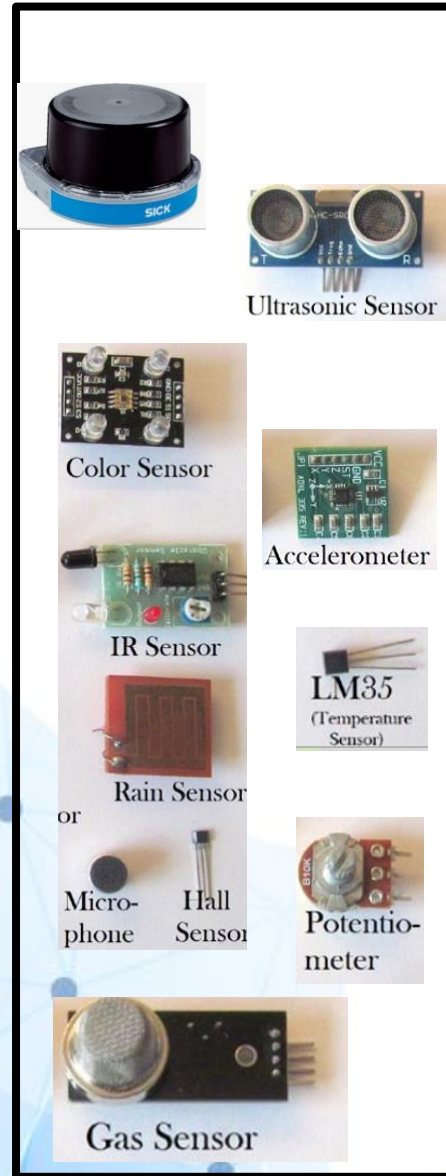

Electronic Signal



Analog Signal

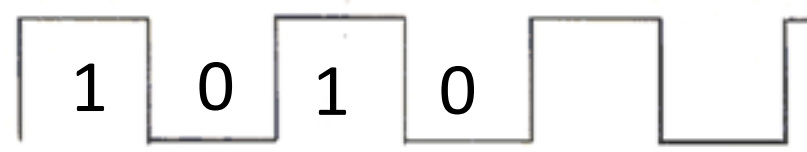

Digital Signal

Brain of the robot



Control System



Numerical computation

Algorithm

Control Method

Data Conversion

AI

Database/
Big Data

Human Machine
Interface

Data from Sensor

Signal for actuator

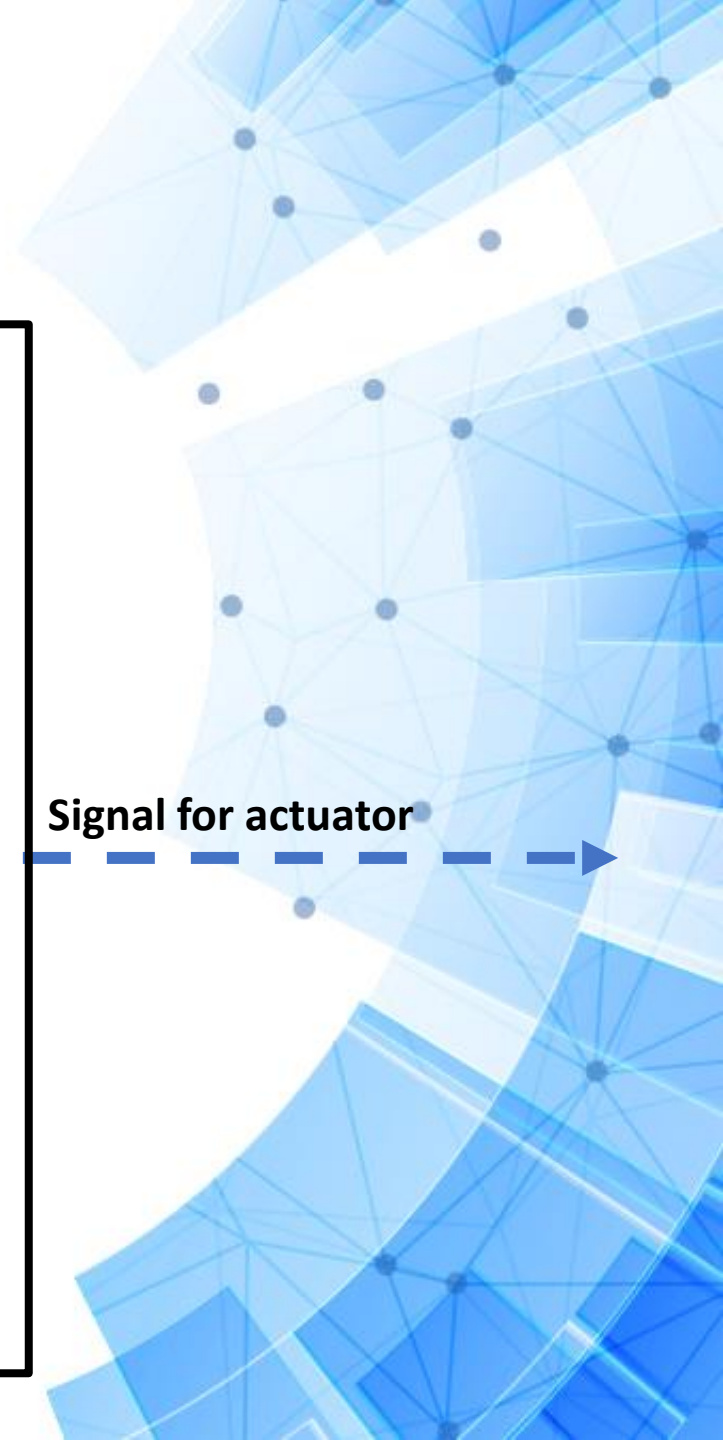

Actuators



Energy source



Signal from controller



Heat

Motion

Magnetic field

On/off Valve

Complete robotics system

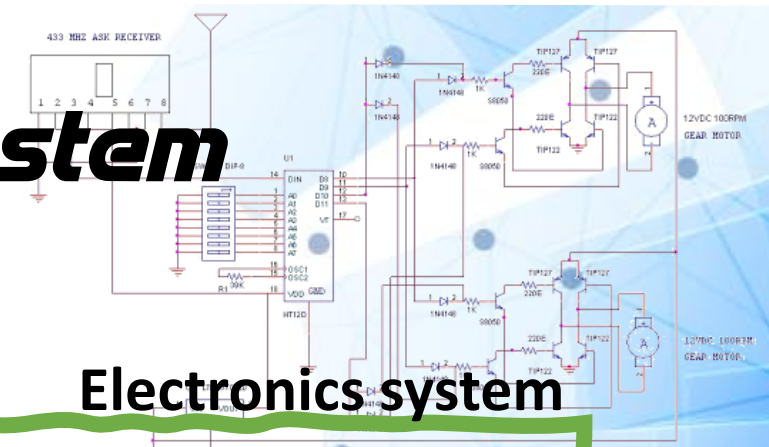
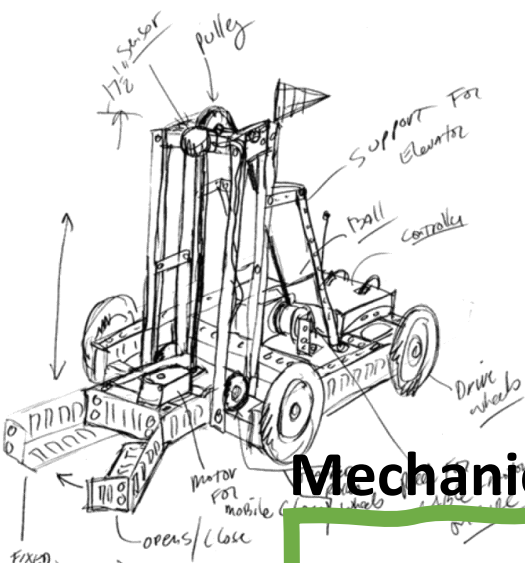

Mechanical construction

Electronics system

SENSOR

CONTROL SYSTEM

ACTUATOR

Software

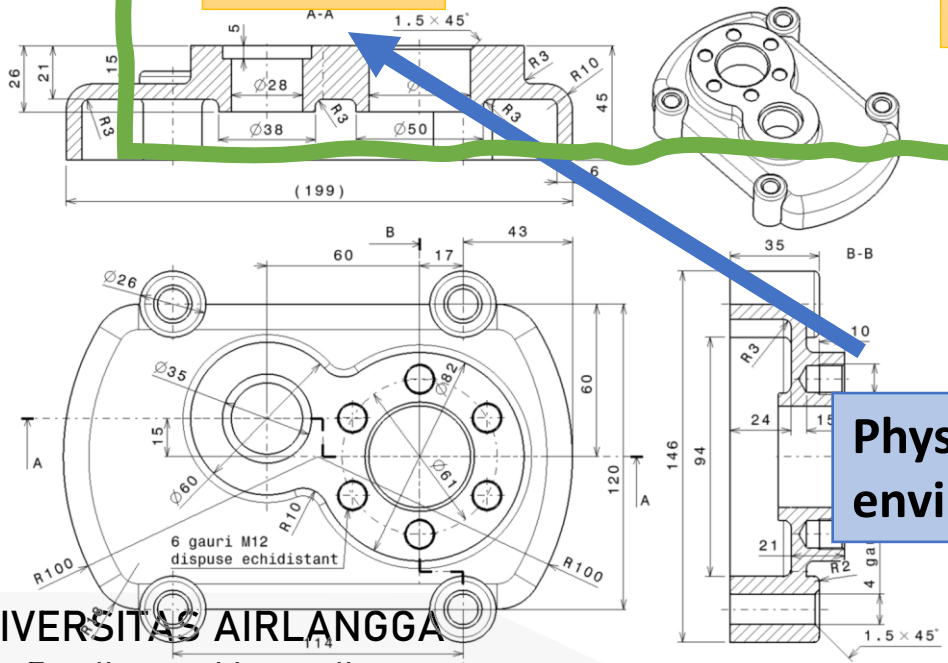

Physical system / robot environment

Networking System



Drones or UAV ??



Fixed Wing UAV



Multirotor UAV



Helicopter UAV

UAV stands for **Unmanned Aerial Vehicle**, something that can fly without a pilot onboard

How Drones Work

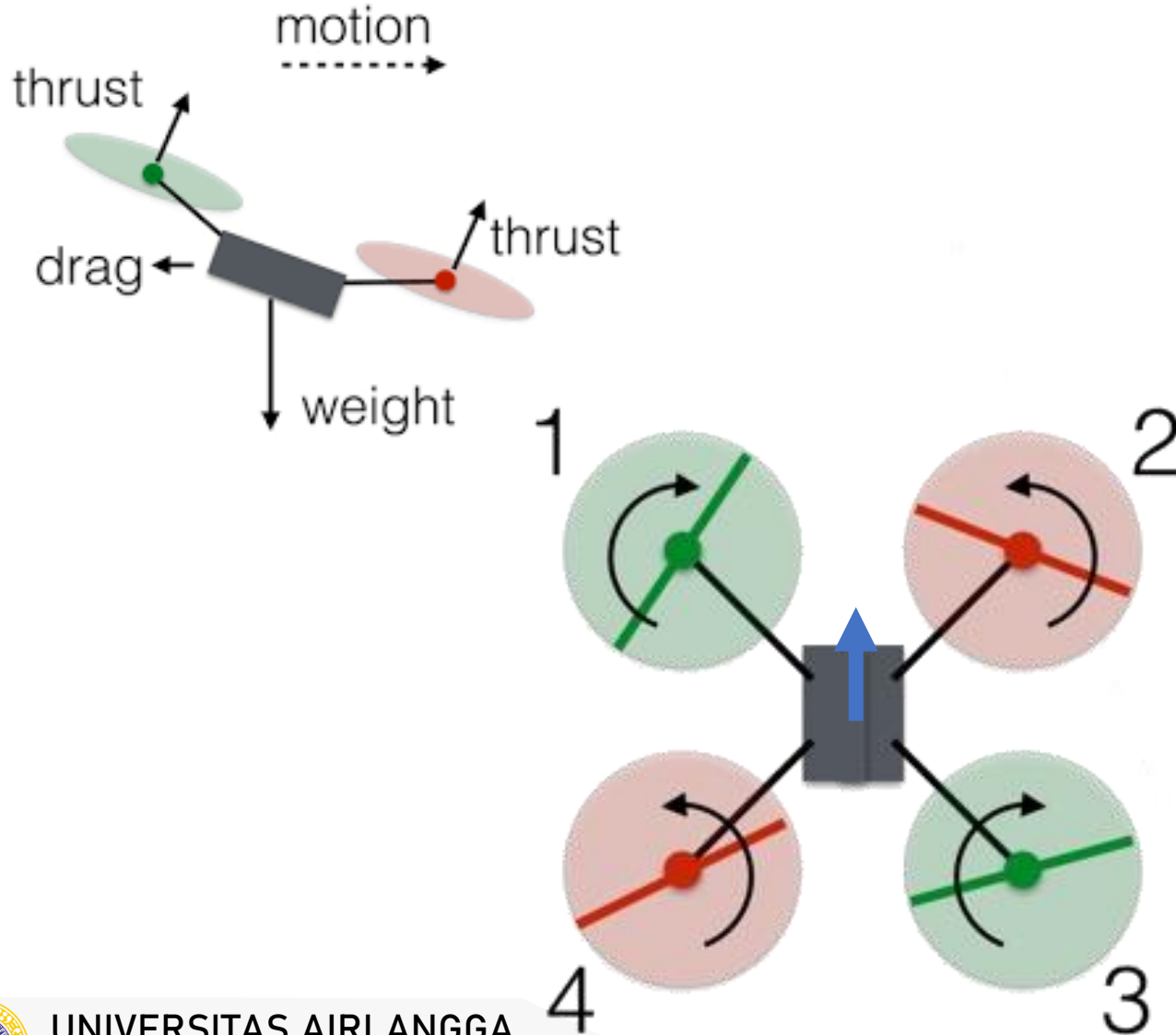

Kelebihan:

- Reliable
- Compact
- Low maintenance
- Minimal space untuk take off dan Landing

Kekurangan

- Limited payload
- Limited flight time

Drone Development & Type



De Bothezat Helicopter, 1923



Parrot Ar-Drone 2010



DJI Mavic 3 , 2020



Hobby / Riset / Custom



Mainan

Drone Components (Basic)

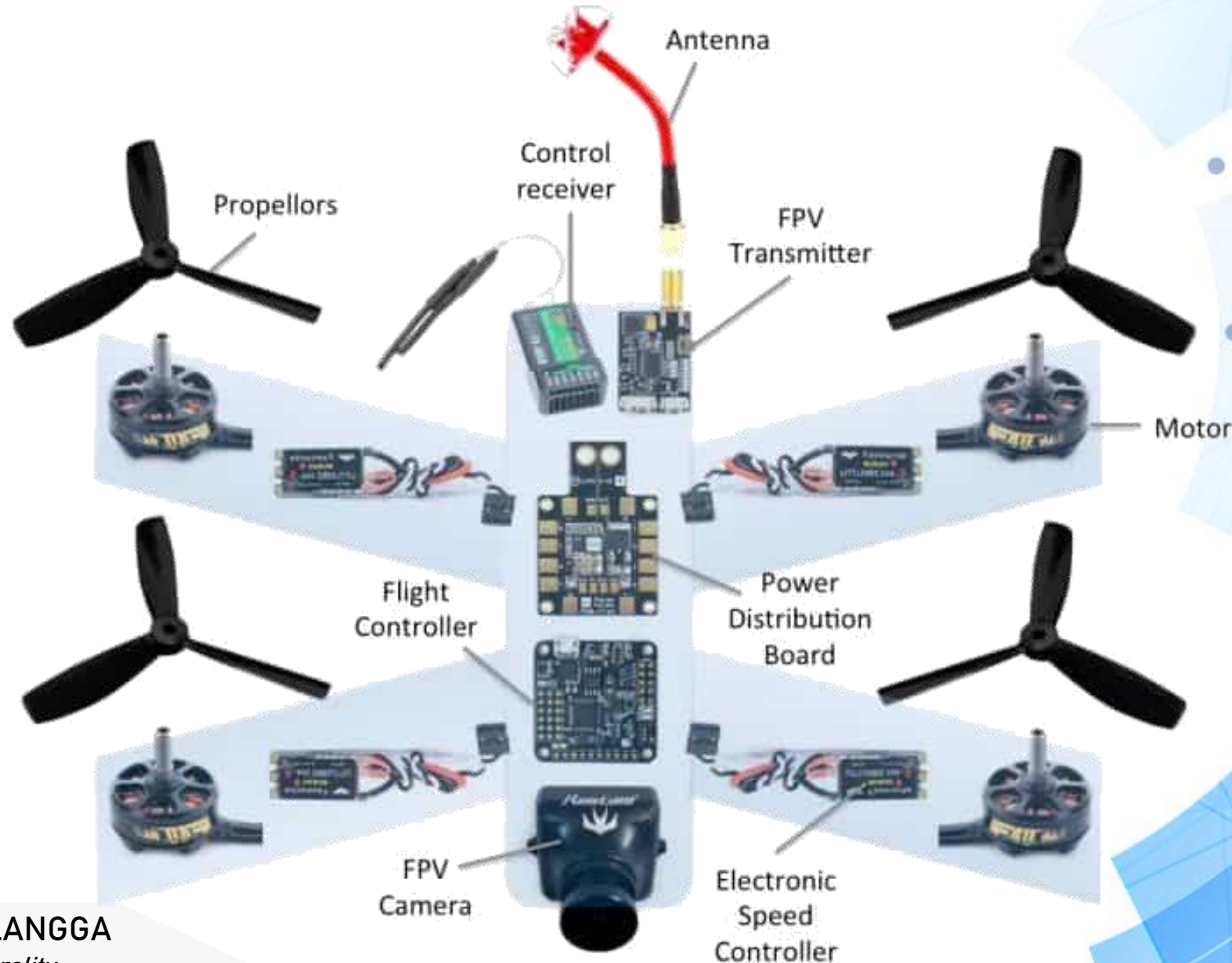

DIY Autonomous Drone Solution

ARDUPILOT
Versatile, Trusted, Open

HOME ABOUT BLOGS USE CASES DOCS STORES COMMUNITY



<https://ardupilot.org/>

Ardupilot Ground Control Station (Basic)



Mission Planner 1.3.37 build 1.1.5917.13431 APM:Copter V3.3 (d6053245)

FLIGHT DATA | FLIGHT PLAN | INITIAL SETUP | CONFIG/TUNING | SIMULATION | TERMINAL | HELP | DONATE

285 300 NW 330 34145 N 15 30

DISARMED

AS 0.0 GS 0.0 Guided 4747>0

Bat 12.59v 0.0 A 100% EKF Vibe GPS: 3D Fix

Quick Actions PreFlight Gauges Status Servo Telemetry Logs DataFlash Logs Scripts Mes

hddop: 1.2

Sats: 10 **Classed** **Headed** **Direct to current WP** **Signal Good** **GPS Track (Black)**

GEO -35.363261 149.165230 0.00m Tuning Auto Pan Zoom 11.0

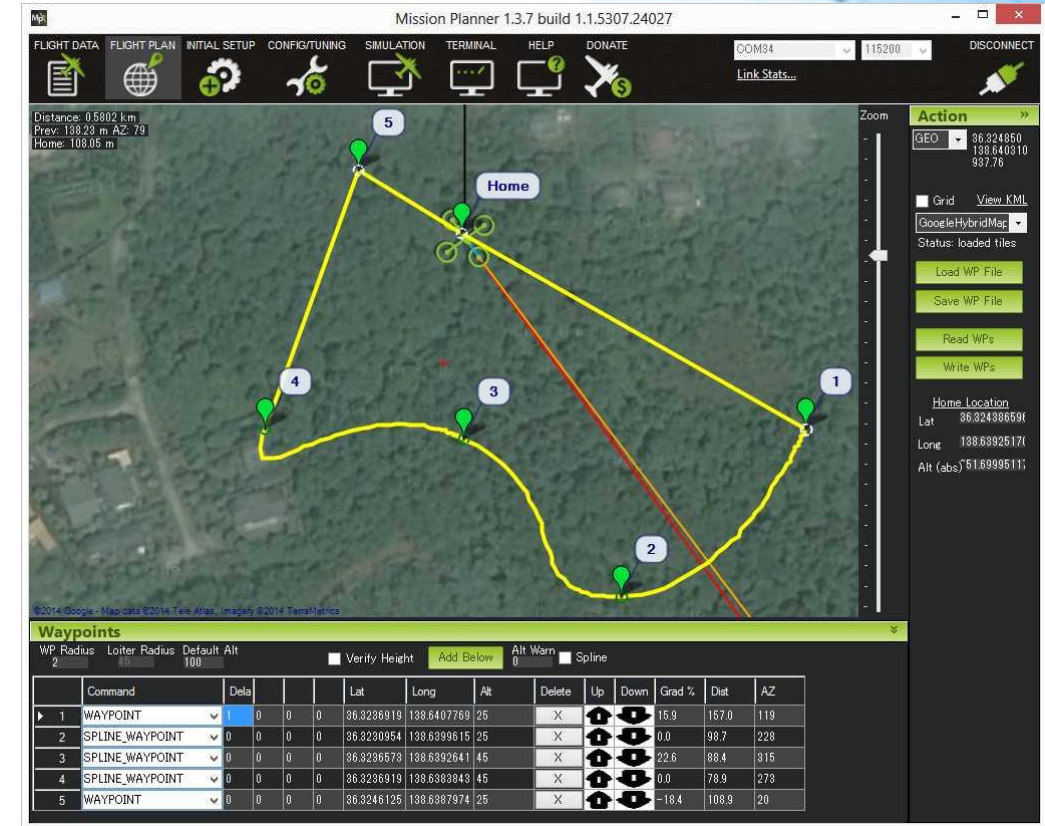

Mission Planner 1.3.7 build 1.1.5307.24027

FLIGHT DATA | FLIGHT PLAN | INITIAL SETUP | CONFIG/TUNING | SIMULATION | TERMINAL | HELP | DONATE

Distance: 0.6802 km Prev: 139.23 m AZ: 79 Home: 108.05 m

Waypoints

	Command	Delay	Lat	Long	Alt	Delete	Up	Down	Grad %	Dist	AZ
1	WAYPOINT	0	36.3236919	138.6407769	25	X			15.9	167.0	119
2	SPLINE_WAYPOINT	0	36.3230954	138.6399615	25	X			0.0	98.7	228
3	SPLINE_WAYPOINT	0	36.3236573	138.6392641	45	X			22.6	88.4	315
4	SPLINE_WAYPOINT	0	36.3236919	138.6383843	45	X			0.0	78.9	279
5	WAYPOINT	0	36.3246125	138.6387974	25	X			-18.4	108.9	20

Soft Robotics

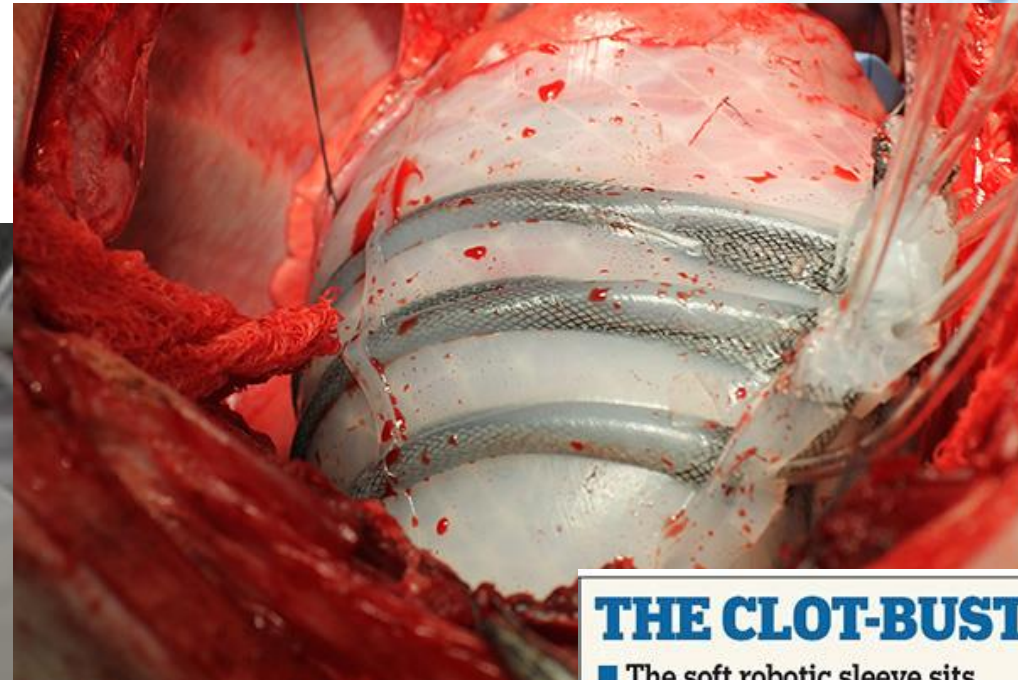

THE CLOT-BUSTER

■ The soft robotic sleeve sits outside the heart. It is a silicone sleeve just 1.5mm thick

■ Air pumped into the artificial muscles, arranged in bands, makes the sleeve contract, mimicking the contraction of a heart

■ Because the device does not come into contact with blood like a conventional artificial heart, anti-clotting drugs to keep the blood flowing are not necessary

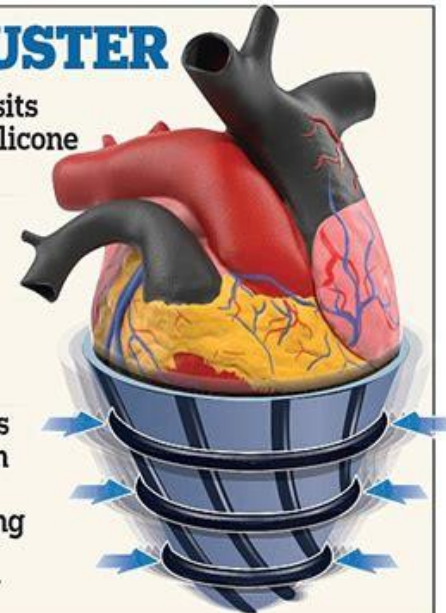

Drone for Medical Transport Concept

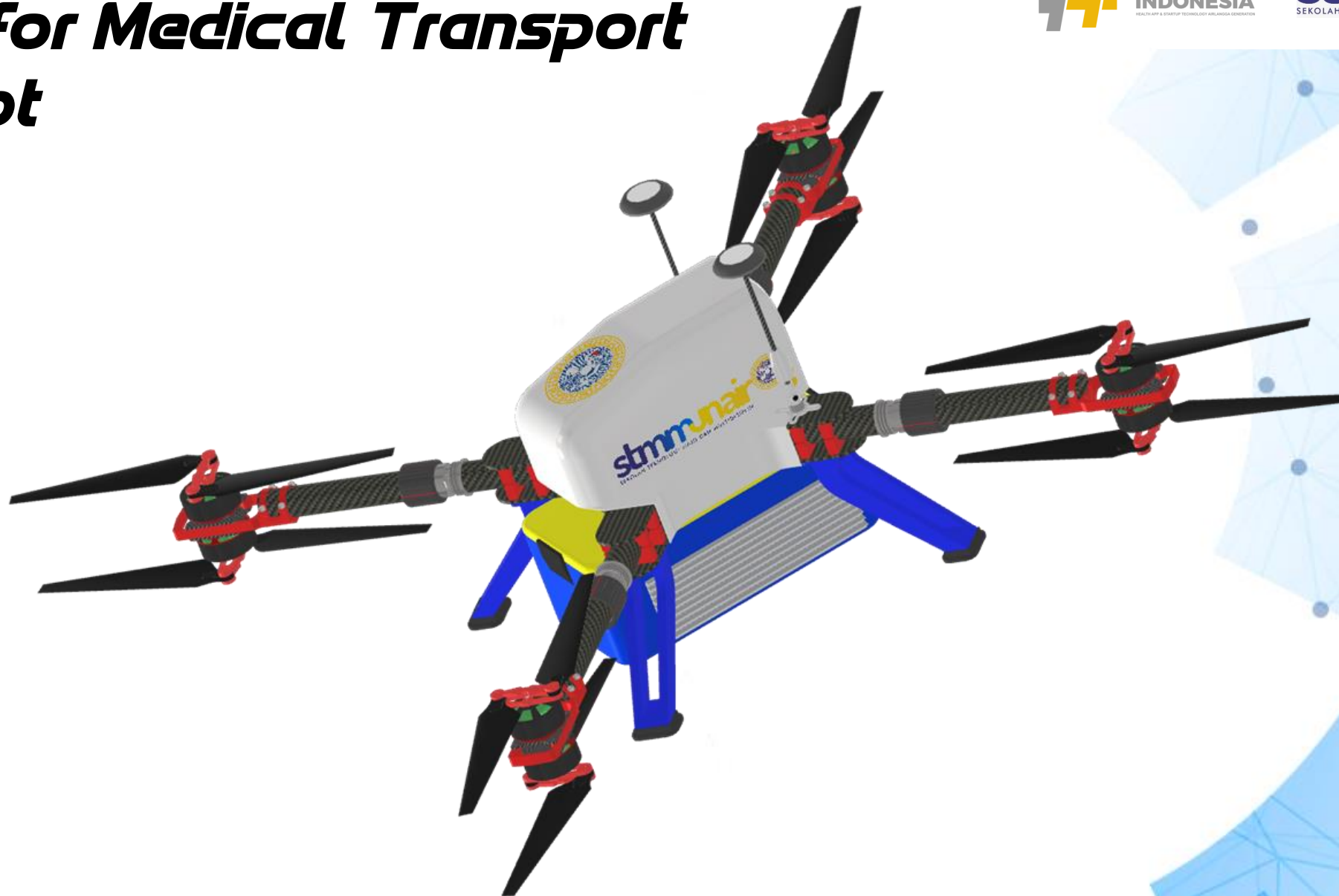

Drone Key Feature

- Coaxial X8 (8 Motor) -> Focus on Speed and Load
- Carbon Fiber Frame (Produksi sendiri)
- Dual GPS
- Foldable Frame & Propeller
- Changeable Payload box / easy to remove
- Open Source platform (Ardupilot)
- Compact Design
- Flight Time estimation (20 Minutes)
- Max Load 5Kg
- Total Weight Estimation 10-12Kg

